



SA-DACT Dialer Installation Sheet

Operation

The SA-DACT transmits system status changes (events) to compatible digital alarm communicator receivers over the public switched telephone network. The SA-DACT queues messages and transmits them based on priority (alarm, supervisory, trouble, disable, test, monitor, and system). The dialer is capable of single, dual, or split reporting of events to two different account and telephone numbers. The modem feature of the SA-DACT can also be used for uploading and downloading panel configuration, history, and current status to a PC running the configuration utility. The modem feature uses line 1 only.

Note: The SA-DACT is compatible with Contact ID (CID) only.

Installation

The DACT is installed on the plastic assembly and connects to the main circuit board via a ribbon cable.

To install the DACT:

1. Power down the panel and disconnect the batteries.
2. Locate the dialer card slot on the plastic assembly behind the main circuit board and connector J8 on the main circuit board (at the top-center of the main board).
3. Slide the DACT into the slot on the plastic assembly as shown in the diagram.
4. Attach the DACT to the plastic assembly using two #6 plastite screws as shown in the diagram.
5. Connect the ribbon cable (P/N 7140188) from the DACT to connector J8 on the main circuit board.
6. Connect the phone lines. See "Wiring."
7. Power up the panel and connect the batteries.

Figure 1: Slide the DACT into its slot

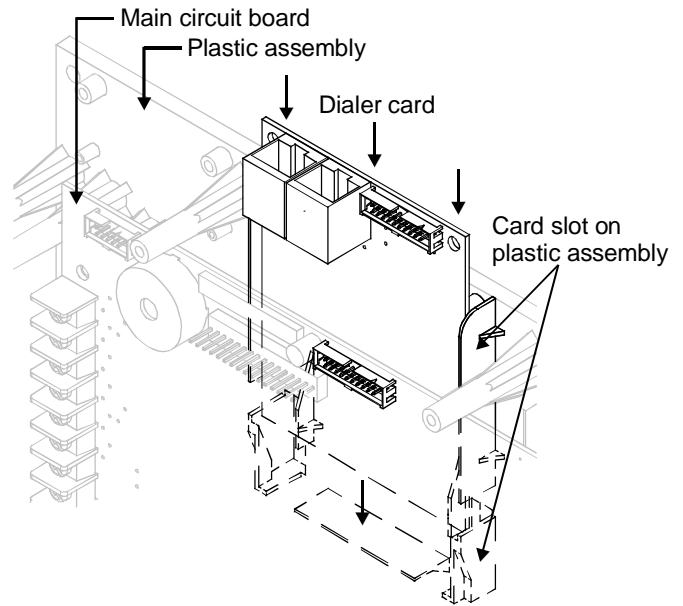
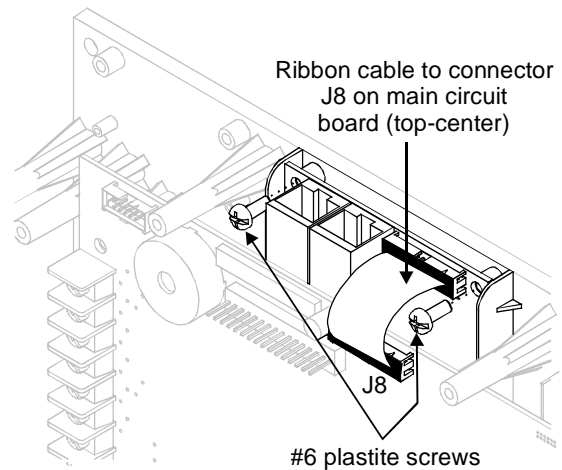

Figure 2: Screw the DACT in place and connect the ribbon cable



Wiring

The dialer phone lines connect to connectors on the dialer's main circuit board. Phone line 1 connects to connector J1 and phone line 2 connects to connector J4.

The card typically connects to an RJ-31X block using an 8-position, 4-conductor modular cord. Wire the RJ-31X block as shown below.

Note: Install a listed secondary telephone protector between the telco network and the SA-DACT card. The SA-DACT card must be the next piece of equipment that connects to the telephone company (TELCO) telephone lines.

Refer to the *Cellular Capture Module Configuration Application Guide* (P/N 3102371-EN) for specific settings and wiring that must be used to meet UL and ULC Agency requirements for FACU communication with cellular capture modules.

The optional Panel Presence Failure Condition (PPFC) offered in the cellular capture modules is *not* supported when the module is connected to line 2 of the SA-DACT. The cellular capture module must be connected to line 1 if the PPFC function is selected.

Figure 3: SA-DACT wiring

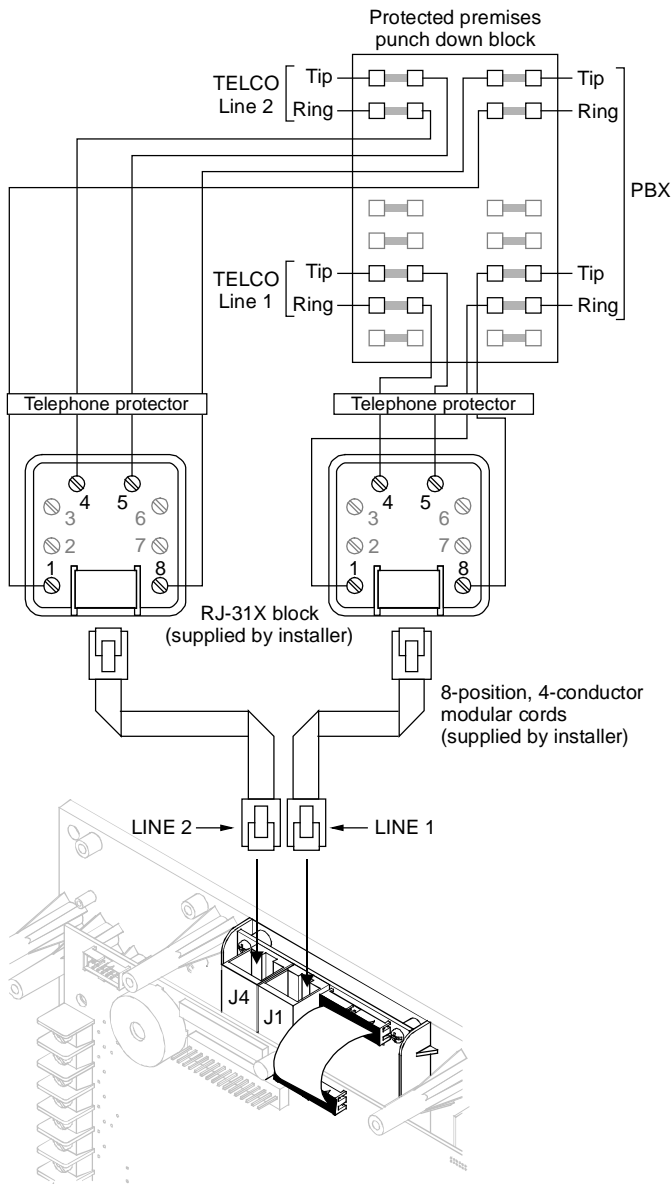

Testing

A dialer test is a test of the telephone line for each dialer account. When a dialer is tested, a normal or abnormal test message (depending on the state of the system) is sent to the selected account. If the dialer is set up for dual line operation, a test message is sent to both lines regardless of the success of the transmission for either account.

Note: Before conducting a test, configure the dialer's accounts for proper operation.

To conduct a dialer test:

1. Press the control panel's Menu button.
2. Choose Test.
3. Choose Dialer.
4. Select the account that you want to test.
5. Press Enter.

Note: The test message is sent to the CMS account that you selected. For verification of the CMS account receiving the test message, you must be in contact with the CMS account during the test. Nothing is displayed on the LCD display.

6. Press Cancel to return to the previous menu.

– or –

Press the Menu button to exit menu mode.

Specifications

Phone line type	One or two loop-start lines on a public, switched network
Phone line connector	RJ-31/38X (C31/38X)
Communication formats	Contact ID (SIA DC-05)
Operating voltage	24 VDC
Operating current	Standby/Alarm: 41 mA Max.: 100 mA
FCC registration number	GESAL01BSADACT
Industry Canada Registration number	3944A-SADACT
Ringer equivalence number	0.1B
Operating environment	
Temperature	32 to 120°F (0 to 49°C)
Humidity	0 to 93% RH, noncondensing at 90°F (32°C)

Compatibility

Refer to the panel compatibility list for compatible receivers and cellular capture modules.

FCC information

Cautions

- To ensure proper operation, this dialer must be installed according to the enclosed installation instructions. To verify that the dialer is operating properly and can successfully report an alarm, it must be tested immediately after installation, and periodically thereafter, according to the enclosed test instructions.
- In order for the dialer to be able to seize the phone line to report an alarm or other event when other customer equipment (telephone, answering system, computer modem, etc.) connected to the same line is in use, the dialer must be connected to a properly installed RJ-31X jack. The RJ-31X jack must be connected in series with, and ahead of, all other equipment attached to the same phone line. Series installation of an RJ-31X jack is depicted in the wiring diagram. If you have any questions concerning these instructions, you should consult your telephone company or a qualified installer.

Testing

When programming emergency numbers or making test calls to emergency numbers, remain on the line and briefly explain to the dispatcher the reason for the call. Perform programming and testing activities in the off-peak hours, such as early morning or late evenings.

Compliance

- **For equipment approved before July 23, 2001:** This dialer complies with Part 68 of the FCC rules. A label attached to the dialer contains, among other information, the FCC registration number and ringer equivalence number (REN) for this equipment. If requested, this information must be provided to the telephone company.
For equipment approved after July 23, 2001: This dialer complies with Part 68 of the FCC rules and the requirements adopted by the Administrative Council for Terminal Attachments (ACTA). A label attached to the dialer contains, among other information, a product identifier in the format US:AAAEQ##TXXXX. If requested, this information must be provided to the telephone company.
- The plug and jack used to connect the dialer to the premises wiring and telephone network must comply with the applicable FCC Part 68 rules and requirements adopted by ACTA. The dialer must be connected to a compliant RJ-31X or RJ-38X jack using a compliant cord. If a modular telephone cord is supplied with the dialer, it is designed to meet these requirements. See installation instructions for details.
- A ringer equivalence number (REN) is used to determine how many devices you can connect to a telephone line. If the total REN value for all devices connected on a telephone line exceeds that allowed by the telephone company, the devices may not ring on an incoming call. In most (but not all) areas the total REN value should not exceed 5.0. To be certain of the total REN value allowed on a telephone line, contact the local telephone company.

For products approved after July 23, 2001, the REN is part of the product identifier in the format US:AAAEQ##TXXXX. The digits ## represent the REN without a decimal point. Example: 03 is an REN of 0.3. For earlier products the REN is listed separately.

- If the dialer is harming the telephone network, the telephone company will notify you in advance that temporary discontinuance of service may be required. If advance notice isn't practical, the telephone company will notify you as soon as possible. You will also be advised of your right to file a complaint with the FCC, if you believe it is necessary.
- The telephone company may make changes to its facilities, equipment, operations, or procedures that could affect the operation of the dialer. If this happens, the telephone company will provide advance notice in order for you to make necessary modifications to maintain uninterrupted service.
- If you are experiencing problems with the dialer, contact EST Technical Support for repair or warranty information. If the dialer is harming the telephone network, the telephone company may request that you disconnect the dialer until the problem is resolved.
- The dialer contains no user serviceable parts. In case of defects, return the dialer for repair.
- You may *not* connect the dialer to a public coin phone or a party line service provided by the telephone company.

Industry Canada information

Note: The Industry Canada label identifies certified equipment. This certification means that the equipment meets certain telecommunications network protective, operational, and safety requirements. Industry Canada does not guarantee the equipment will operate to the user's satisfaction.

Before installing this equipment, users should ensure that it is permissible to be connected to the facilities of the local telecommunications company. The equipment must also be installed using an acceptable method of connection. The customer should be aware that compliance with the above conditions may not prevent degradation of service in some situations.

Repairs to certified equipment should be made by an authorized Canadian maintenance facility designated by the supplier. Any repairs or alterations made by the user to this equipment, or equipment malfunctions, may give the telecommunications company cause to request the user disconnect the equipment.

Caution: Users should not attempt to make connections themselves, but should contact the appropriate electric inspection authority, or electrician, as appropriate.

Users should ensure for their own protection that the electrical ground connections of the power utility, telephone lines, and internal metallic water pipe system, if present, are connected together. This precaution may be particularly important in rural areas.

Note: The Load Number (LN) assigned to each terminal device denotes the percentage of the total load to be connected to a telephone loop which is used by the device, to prevent overloading. The termination on a loop may consist of any combination of devices subject only to the requirements that the sum of the Load Numbers of all the devices does not exceed 100.

Contact information

For contact information, see www.edwardsfiresafety.com.